

**Pièce n°1 : bride plate Ø 150**

**échelle 1/2**

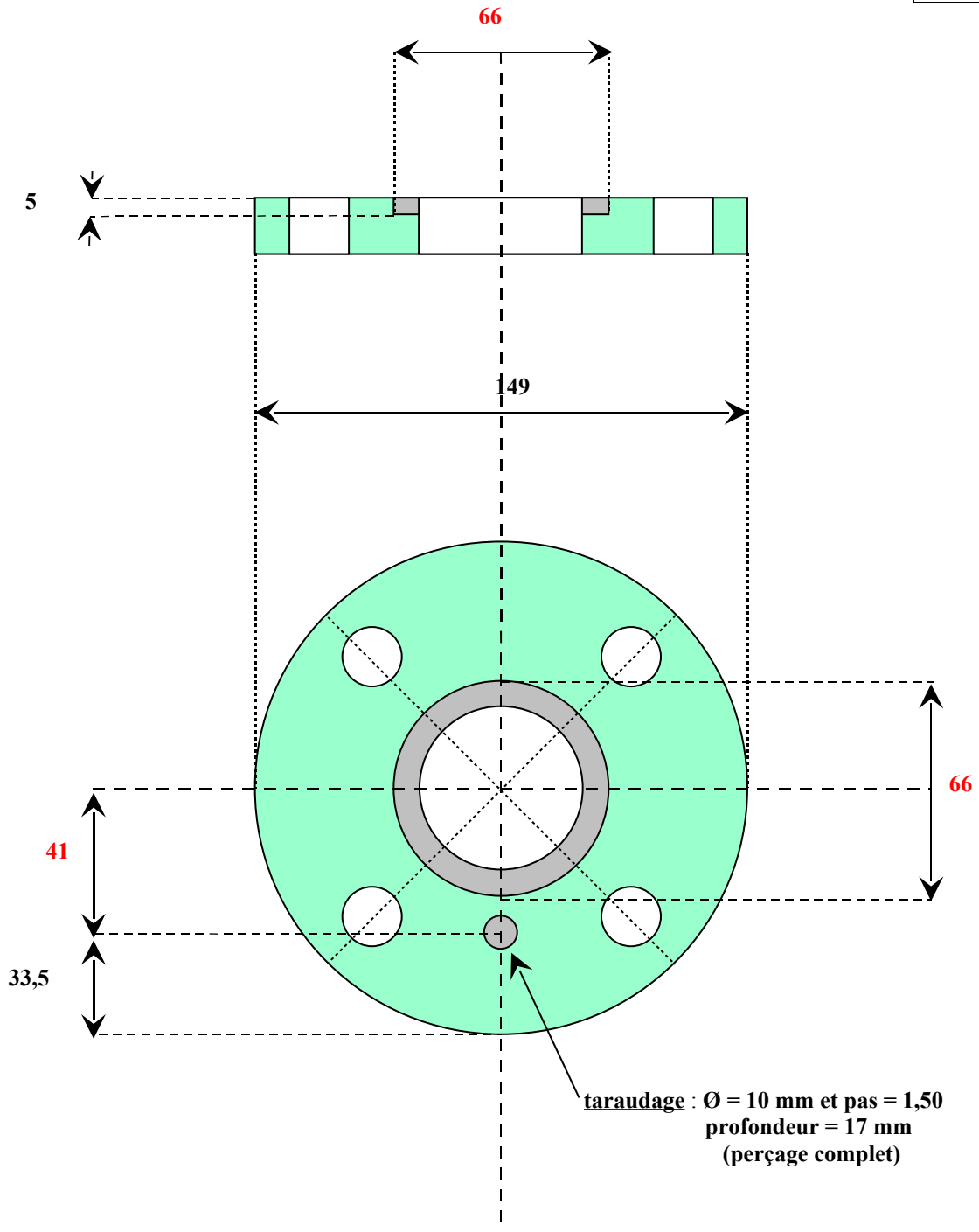

 = parties à enlever

**Pièce n°2 : bride pleine Ø 250**

**échelle 1/2**

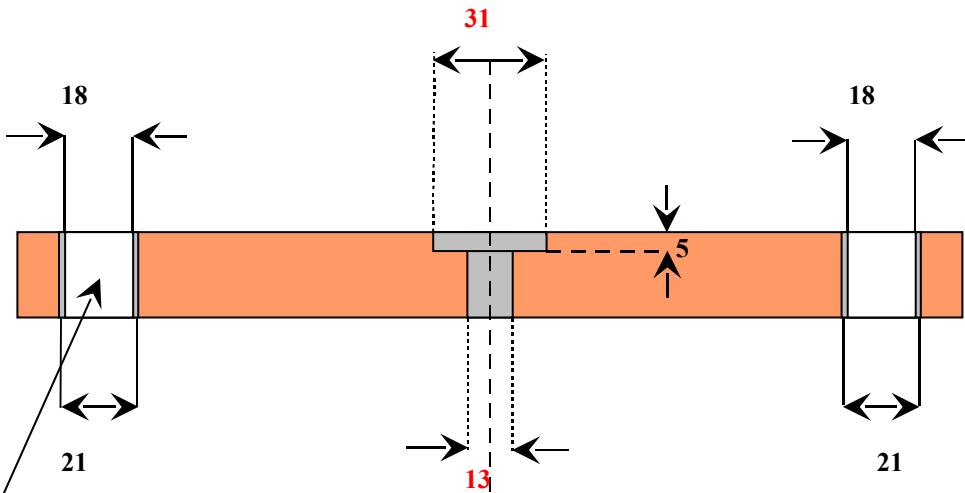

**trou initial : Ø = 18**  
**trou final : Ø = 21**

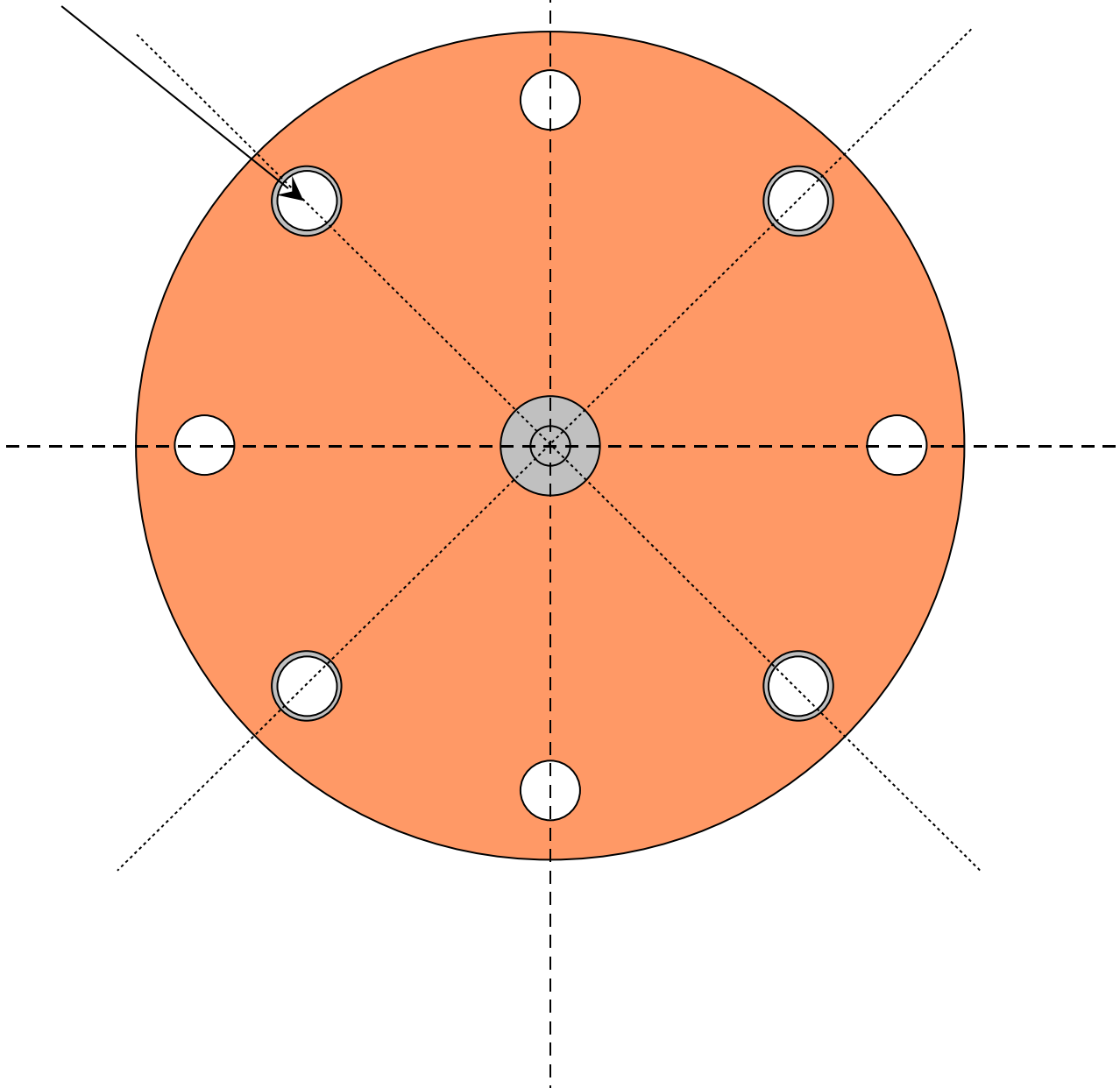

**Pièce n°3 : butée d'azimut**

échelle 1/2

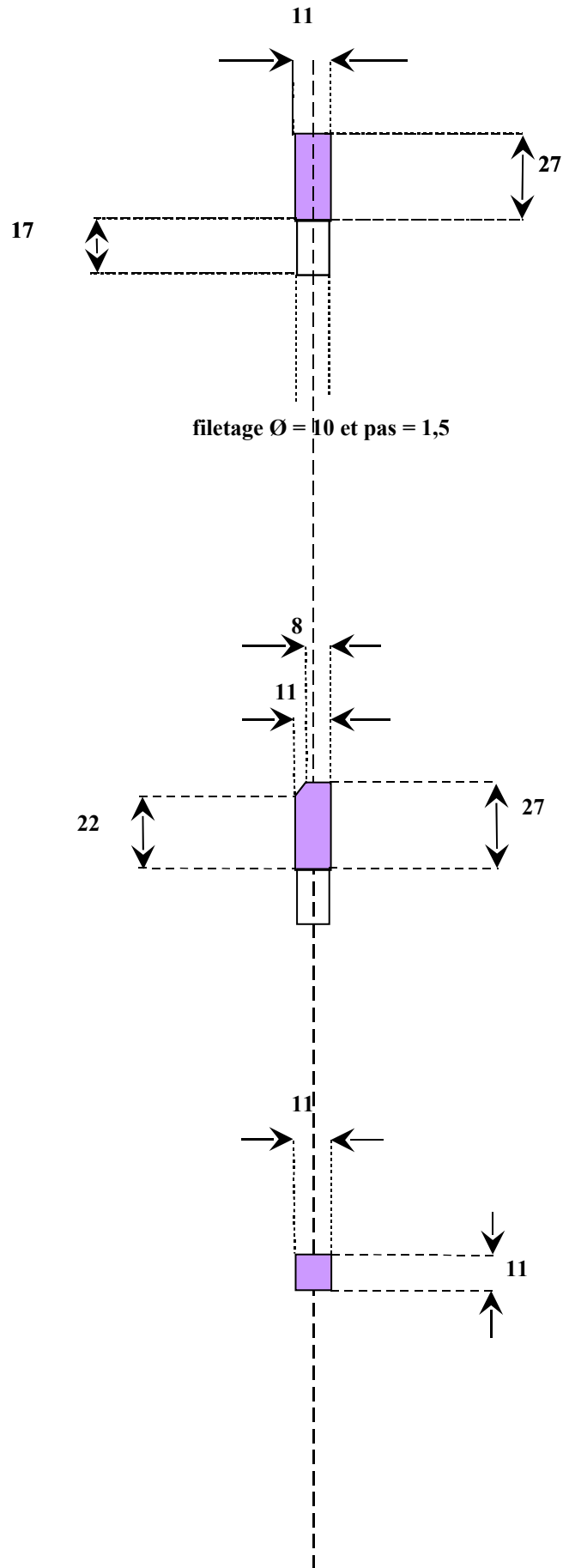

**Pièce n°4 : vis serrage**

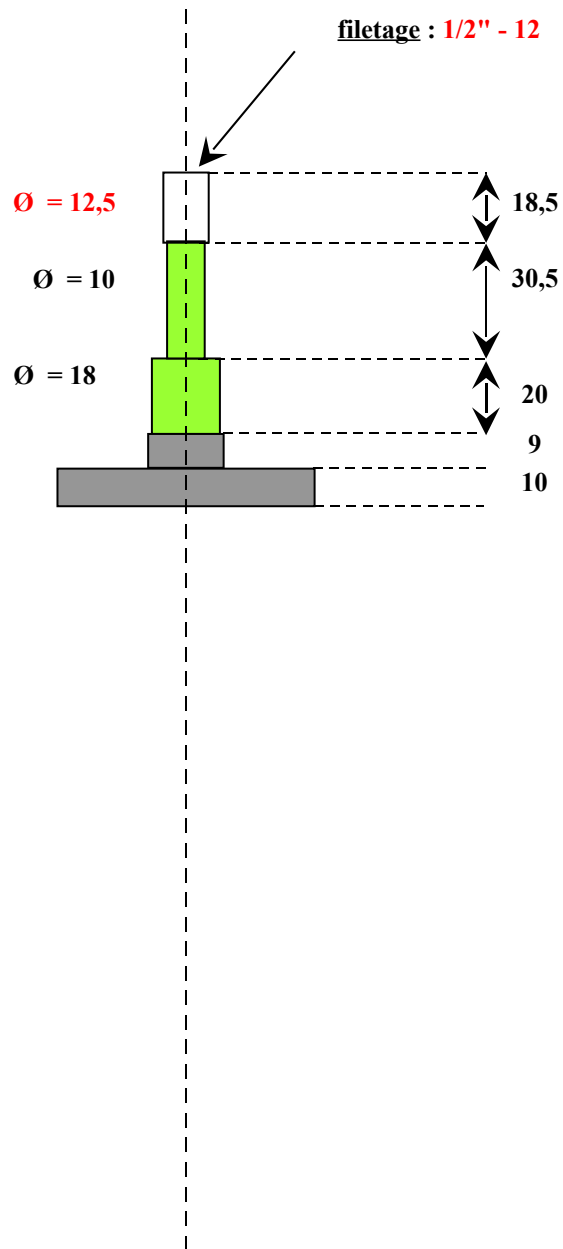

**Pièce n°5 : platine sommet colonne**

